

About Luna Eyes - Dual

SOLAR + AC POWERED STREET AND COURTYARD LIGHT



The Luna Eyes - Dual (Solar + AC Powered Street and Courtyard Light) is a truly remarkable offering by the Luna Street Team.

Harnessing both the power of the sun in addition to regular electric current, the Luna Eyes - Dual is the perfect solution for your street and area illumination needs while helping to reduce the energy demand and usage of traditional outdoor lighting products.

The Luna Eyes - Dual is the perfect solution for applications in which you need a direct power backup for added energy security and performance! The Luna Eyes - Dual captures the maximum source energy from the sun during the daytime, and uses this energy during the night for illumination!

Features & Benefits

EASY TO USE!

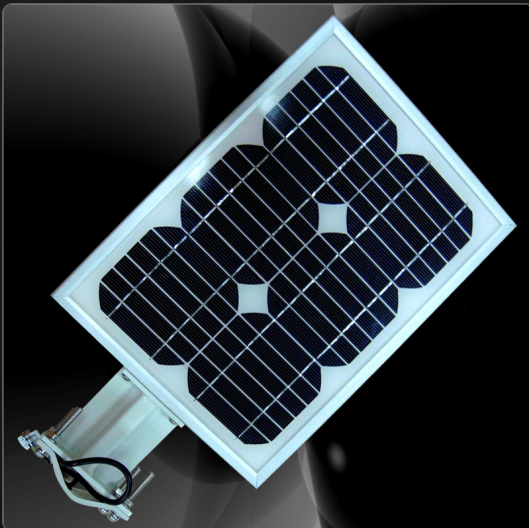

- ▶ Solar Powered outdoor lighting
- ▶ Direct electrical backup power supply for added energy security and enhanced performance levels
- ▶ Uses lithium-ion battery technology to prolong product life
- ▶ Increased brightness and surface area illumination compared to Luna Eyes 1.0
- ▶ Enhanced boosting of solar power creation compared to Luna Eyes 1.0
- ▶ Light output is adjusted automatically via a built-in infrared sensor
- ▶ Increase savings in the short and long term!
- ▶ Use less energy. Save your pocket and the environment!
- ▶ Ease into the Solar Revolution by having an electrical backup for those worried to adopt the new technology!

Technical Data

LUNA EYES DUAL

PHYSICAL SPECIFICATION

Light Source	8 W LED
Solar Module	12 W
Lithium-Ion Battery	Internal
Human Body Infrared Sensor	Yes
Working Voltage	100~240VAC
Overcharge / Discharge Protection	Yes
Luna Eyes Dual Dimensions	563(L)×306(W)×56(H) mm
Net Weight	4.5 KGS

LIGHT OUTPUT

Luminous Flux (type) Bright Mode	680 lm
Dim Mode	200 lm
View Angle	120 degrees
Color Temperature	6000K~7000K
Light Sensitivity (type)	30 lx
** Switches to AC Power when battery is fully exhausted **	

ENVIRONMENTAL RATING

Operating Temperature Range	20°C ~ + 70°C
Storage Temperature Range	20°C ~ + 70°C
IP Rating	IP65

INSTALLATION

Installation Height	3 ~ 4 M
<i>* Adjustable to your desired installation specifications</i>	

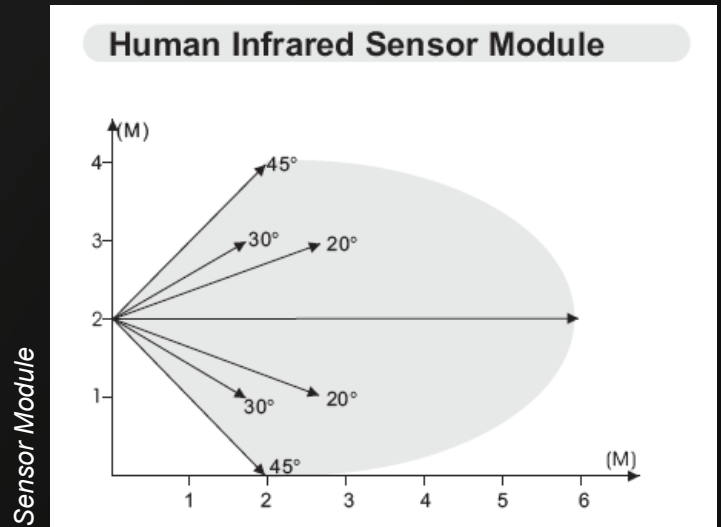
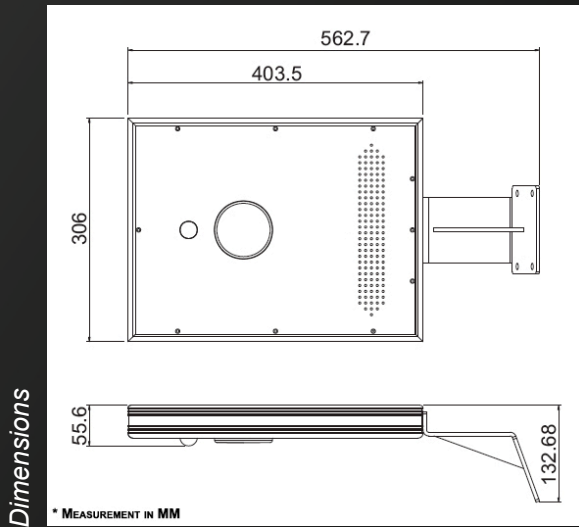

For further technical and pricing information, please contact The Luna Road Team.

info@lunaroad.com

www.lunastreetlight.com

1 800 257 0314